

VKMS 315

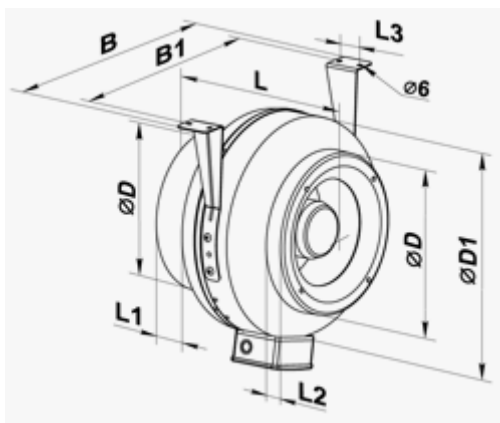

Parameter	Value	Unit
	Voltage	230 V
Current	1.34	A
Frequency	50	Hz
Power consumption	296	W
	0,296	kW
Maximum air consumption	1880	m ³ /h
	1107,32	CFM
	522,64	l/s
	0,52264	m ³ /s
	31396	l/m
RPM	2720	min ⁻¹
Noise level at 3 m	54	dB(A)
Maximal temperature of transferred air	-25 +45	°C
Index of protection	IP X4	class
Weight	8.2	kg
Dimension of connection pipe	315	mm
High-powered motor	yes	
Low-noise design	no	
Energy-efficient motor with low energy demand	no	

VKMS 315



Sizes	ØD	B1	ØD1	B	L	L1	L2	L3
mm	314	414	404	454	288	25	40	40

Ташев-Галвинг ООД
www.tashev-galving.com